

Lift



Clean Energy Elevated

Lift by Spotlight Solar makes a statement – of stewardship. Designed to complement a rooftop solar system or other environmental investments, it reminds people of all the beneficial things you do. Installed in a prominent place, Lift will inspire people to make their own positive impact

Lift's modular design provides flexibility and enhances your site. Position its arms and solar panels to balance energy production and aesthetics. Even color coordinate, add lighting, a place to plug in, and signage – so people will learn about solar as they stand in the shade of beautiful clean energy.



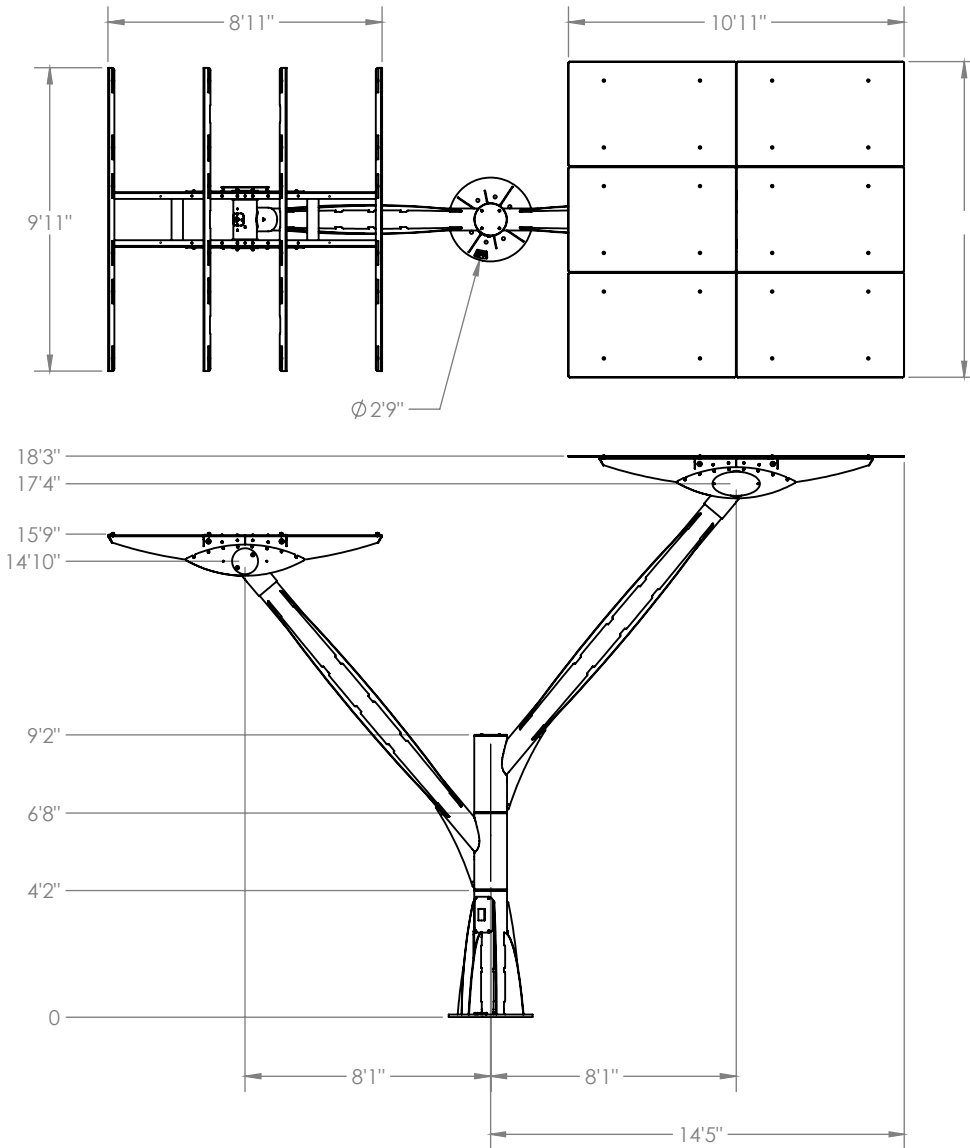
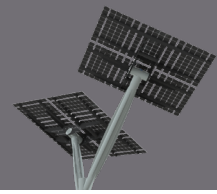

Specifications	
Warranty	10 year limited warranty
Maximum height	22' 6"
Total weight	2,480 lbs. (ships in pieces, heaviest of which is 720 lbs.)
Wind load rating	175 MPH
Material	Recycled steel
Finish	High performance coating, client's color choice
Solar panel requirement	Lumos LSX frameless
<p>Provided by Spotlight Solar: mounting structure, module attachment hardware, installation and orientation guidelines</p> <p>Provided by solar integrator: solar modules, inverter, wiring, foundation, electrical design, installation, permitting, site-specific engineering</p>	
Configuration	Product Number
2-arm (12 panels)	LFT-103082
Accessories	
Accent lighting on joints	ACC-110001
Fin Sign	LFT-170000
Joint Logo Plate	ACC-170001
Power outlet with shelf	LFT-160000
Power outlet	LFT-120000

Updated 9.17.2019

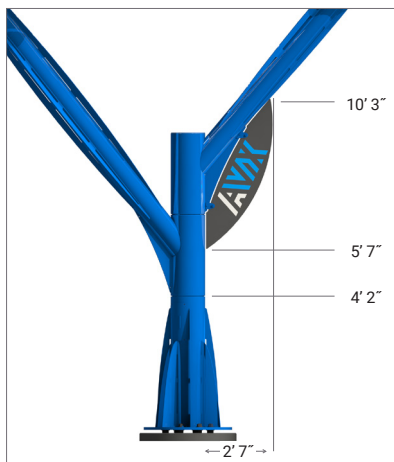

Optional fin sign

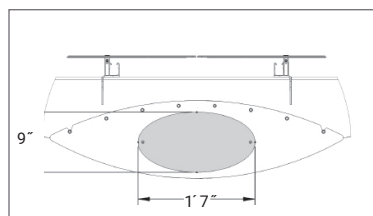

Optional joint logo plate



Optional lighting

Spotlight Solar is up to something good.



Spotlight Solar is dedicated to making solar energy visible and attractive. We don't replace rooftop systems; we complement them. Our ambition is to promote the adoption of solar energy by making it more visible and engaging.